

***MTA1 CAN, M1 10Prog CAN, AT1 CAN,
AT1 CoarseFine CAN, M1, AT1,
AT1 CoarseFine, RA 12, RA 23,
FS 002 CAN, FS 002***



Instruction manual

1 INTRODUCTION	3
1.1 Equipment	3
2 OPERATION	3
2.1 Functions	3
2.2 Cross reference list remote control / machine	5
3 ORDERING SPARE PARTS	5
DIMENSION DRAWING	8
DIAGRAM	10
ORDERING NUMBER	14
ACCESSORIES	15

1 INTRODUCTION

These remote controls can control current, wire feed speed, voltage or program selection.

ESAB's accessories for the product can be found on page 15.

1.1 Equipment

The remote controls are supplied with an instruction manual.



FS 002 CAN and FS 002 are delivered with 5 metres connection cable, for the other remote controls shall the connection cable be ordered separated.



2 OPERATION

Connect the remote control unit to the socket for the remote control on the power source or the wire feed unit.

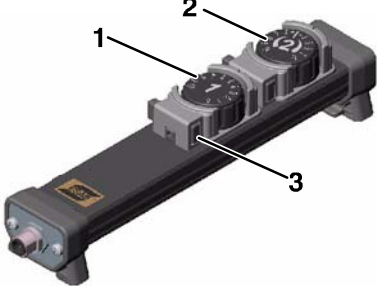
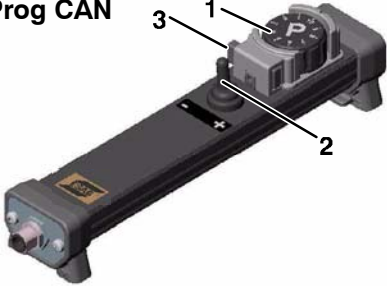
When connecting a remote control in a Aristo machine produced before 2005. The software of the control panel must in some cases be upgraded in order for the remote controls to function correctly.

2.1 Functions

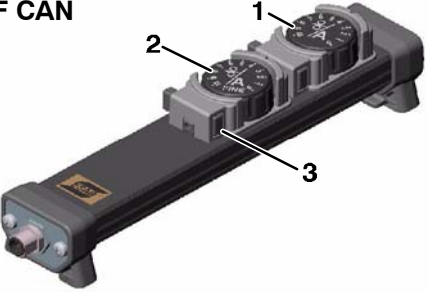
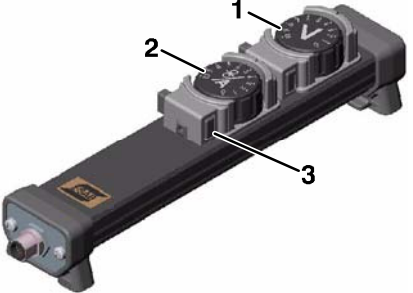
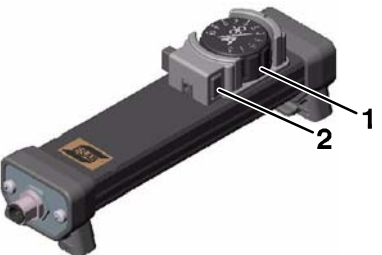
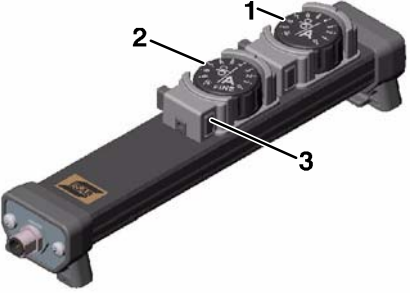
<p>MTA1 CAN</p> 	<p>CAN-based remote control for MIG/MAG, TIG and MMA welding.</p> <p>1 MIG/MAG: Setting wire feed speed TIG: Setting current TIG pulse: Setting pulse current MMA: Setting current</p> <p>2 MIG/MAG: Setting voltage or voltage deviation +/- from the synergic line TIG: No function TIG pulse: Setting background current MMA: Setting arc force</p> <p>3 Locking knob</p>
<p>M1 10Prog CAN</p> 	<p>CAN-based remote control for MIG/MAG, TIG and MMA welding.</p> <p>1 Choice of one of 10 program selections</p> <p>2 MIG/MAG: Voltage deviation +/- from selected program TIG and MMA: Setting welding current +/- from selected program TIG pulse: Setting pulse current +/- from selected program</p> <p>3 Locking knob</p>
<p>AT1 CAN</p> 	<p>CAN-based remote control for MMA and TIG welding.</p> <p>1 Setting current</p> <p>2 Locking knob</p>

<p>AT1 CF CAN</p> 	<p>CAN-based remote control for MMA and TIG welding.</p> <ul style="list-style-type: none"> 1 Rough setting of current 2 Fine setting of current 3 Locking knob
<p>M1</p> 	<p>Remote control for MIG/MAG welding</p> <ul style="list-style-type: none"> 1 Setting voltage 2 Setting wire feed speed 3 Locking knob
<p>AT1</p> 	<p>Remote control for MMA and TIG welding</p> <ul style="list-style-type: none"> 1 Setting current 2 Locking knob
<p>AT1 CF</p> 	<p>Remote control for MMA and TIG welding</p> <ul style="list-style-type: none"> 1 Rough setting of current 2 Fine setting of current 3 Locking knob
<p>RA 12</p> 	<p>CAN-based remote control adapter. Used for connecting remote controls MMA1, MMA2 to CAN-based equipment.</p> <ul style="list-style-type: none"> 1 12-pole socket
<p>RA 23</p> 	<p>CAN-based remote control adapter. Used for connecting welding gun with RS3 program selector, MIG2 (2 knobs) to CAN-based equipment.</p> <ul style="list-style-type: none"> 1 23-pole socket

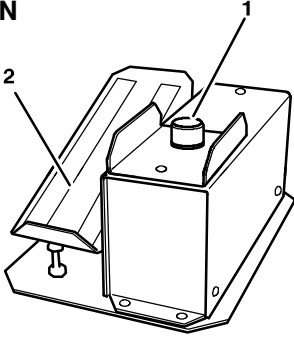
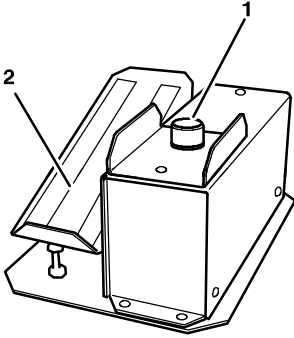
<p>FS 002 CAN</p> 	<p>CAN-based remote control for TIG welding.</p> <p>1 Potentiometer for setting of welding current, positions 1 - 10</p> <p>2 Foot pedal for weld start and setting of welding current.</p> <p>If potentiometer is set at position 10, the current is set, from min. to max. with the foot pedal</p> <p>If potentiometer is set at position 5, the current is set, from min. to 50% of max. current with the foot pedal.</p>
<p>FS 002</p> 	<p>Remote control for TIG welding.</p> <p>1 Potentiometer for setting of welding current, positions 1 - 10</p> <p>2 Foot pedal for weld start and setting of welding current.</p> <p>If potentiometer is set at position 10, the current is set, from min. to max. with the foot pedal</p> <p>If potentiometer is set at position 5, the current is set, from min. to 50% of max. current with the foot pedal.</p>

2.2 Cross reference list remote control / machine

See on page 7.

3 ORDERING SPARE PARTS

Note!

All guarantee undertakings from the supplier cease to apply if the customer himself attempts any work in the product during the guarantee period in order to rectify any faults.

Spare parts may be ordered through your nearest ESAB dealer, see the last page of this publication.

	MTA1 CAN	M1 10P CAN	AT1 CAN	AT1 CF CAN	M1	AT1	AT1 CF	RA12	RA23	FS 002 CAN	FS 002
DTF						X	X				X
DTE/DTG						X	X				X
LHF						X	X				X
Professional						X	X				X
LTN/LTR						X	X				X
Arc 150i						X	X				X
Tig 150i/200i						X	X				X
Feed 304/484, M12					X						
Feed 304/484, M13					X						
ESABFeed M14					X						
MEK (23-polig)					X						
Feed 3004/4804, M2	X								X		
Feed 3004/4804, MA4	X		X						X		
Feed 3004/4804, MA6	X	X	X	X				X	X		
Feed 3004/4804, U6	X	X	X	X				X	X	X	
Feed 3004/4804, M0 / U8	X	X	X	X				X	X	X	
Arc 4000i/5000i, A2	X		X	X				X			
Arc 4000i/5000i, A4	X		X	X				X			
Tig 4000i, T4	X		X	X				X		X	
Tig 4000i, T6	X	X	X	X				X		X	

Dimension drawing

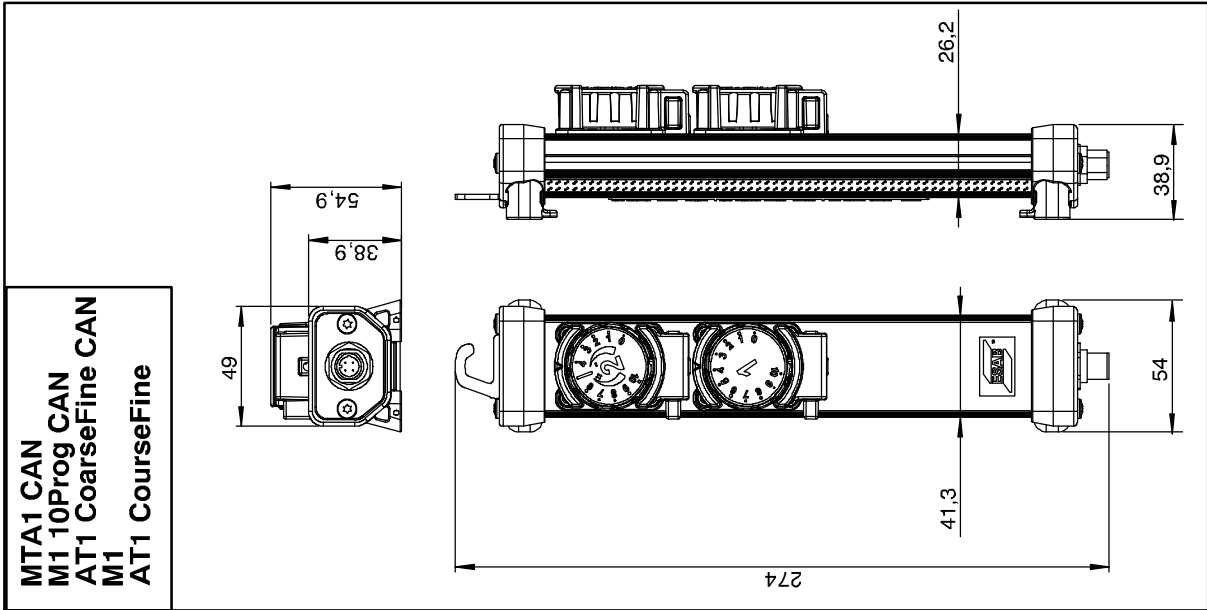
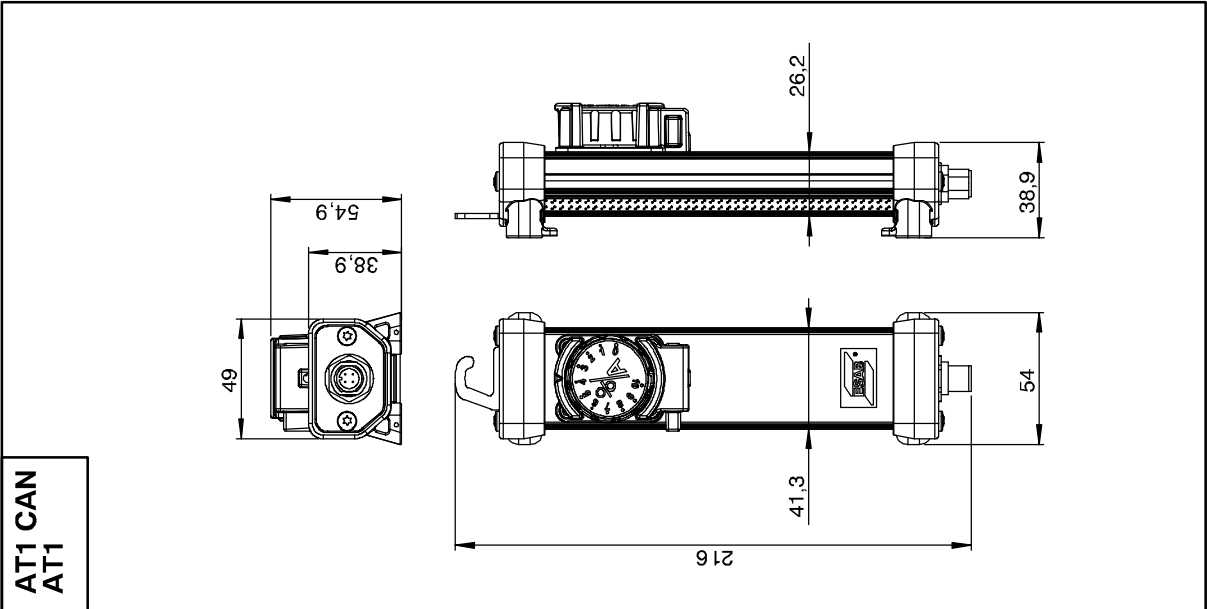
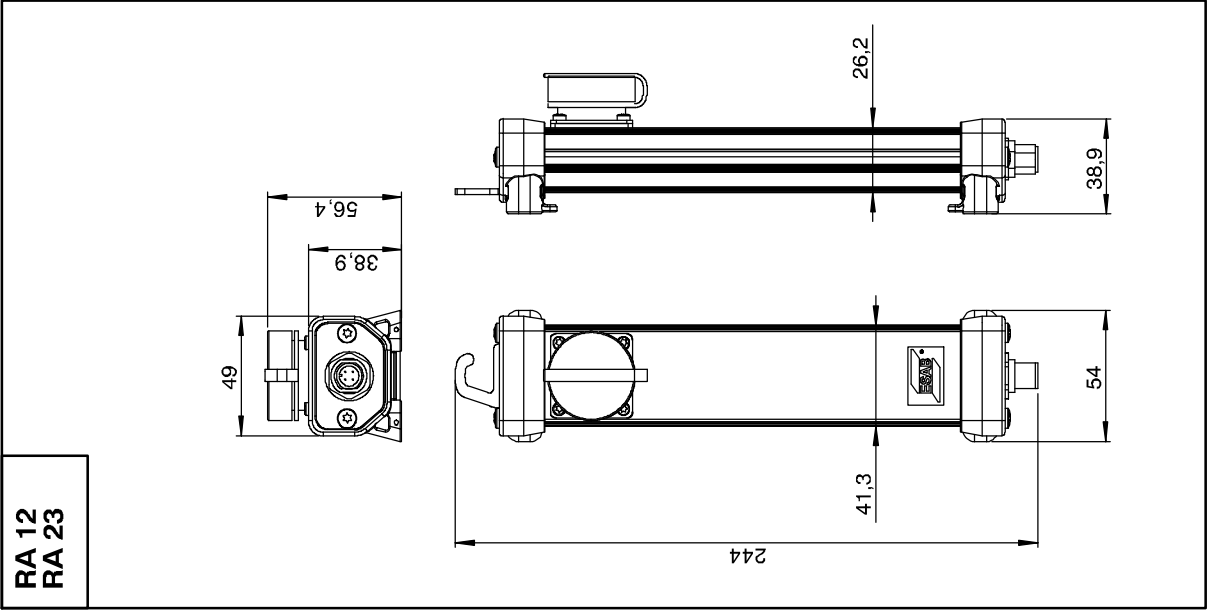

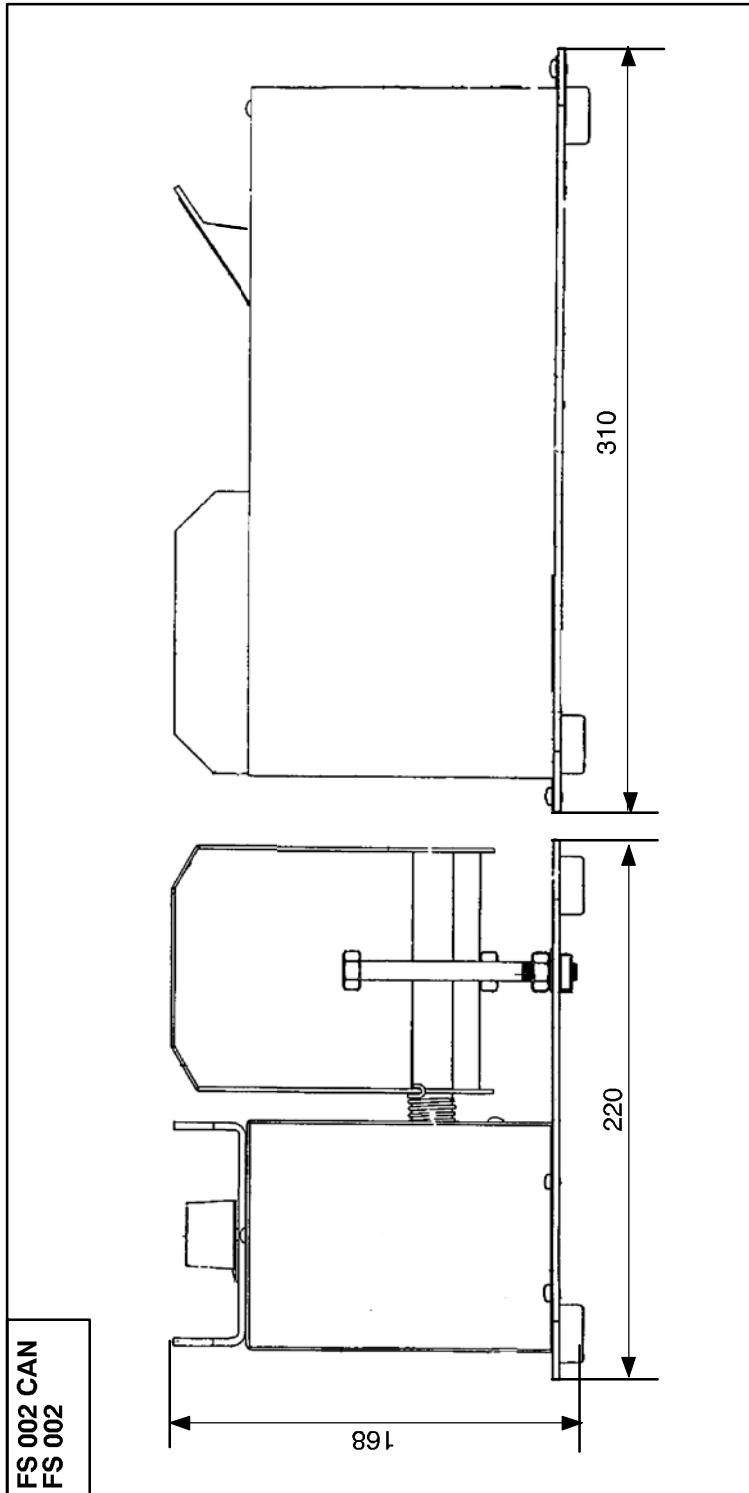

Diagram

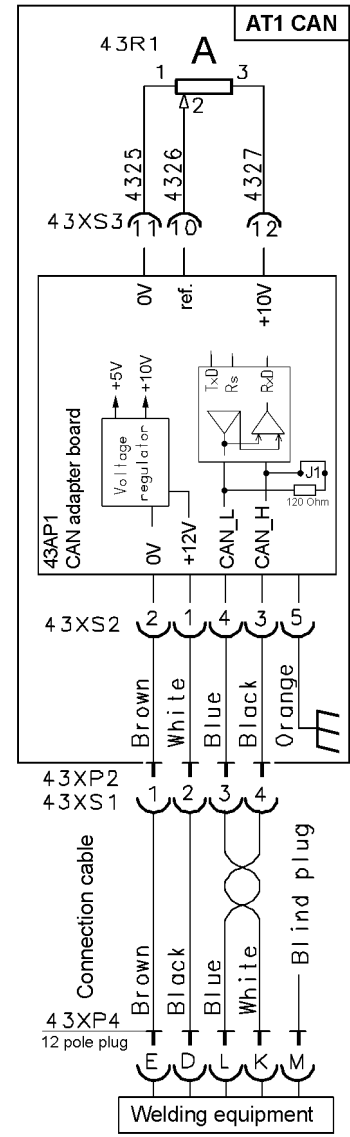
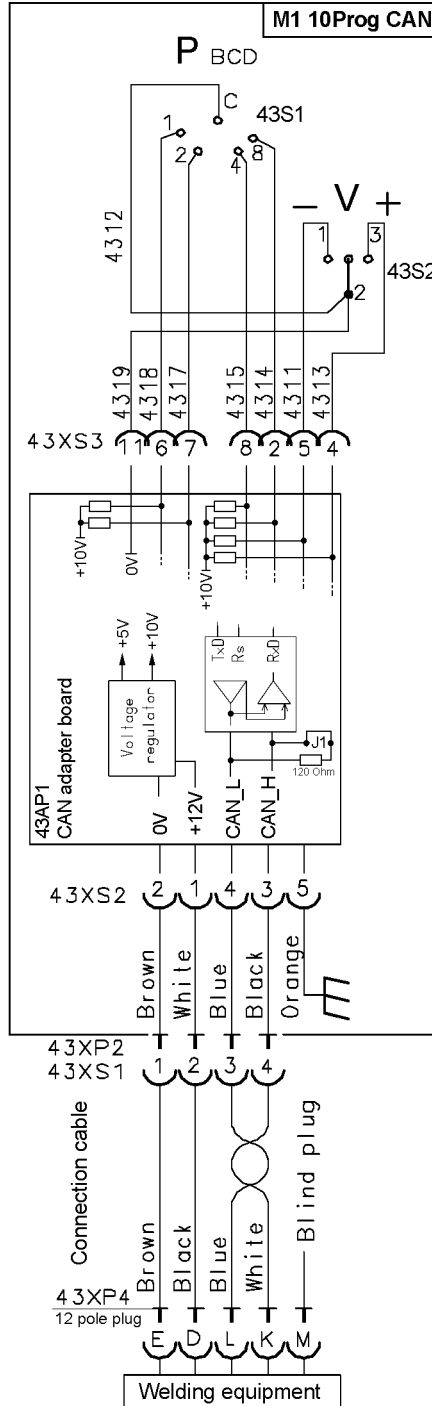
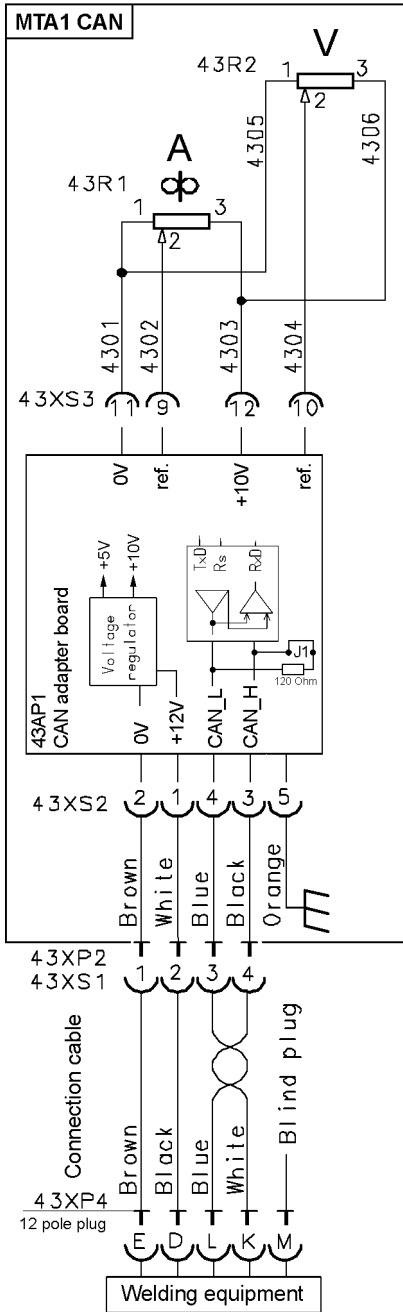

Valid for serial number
506-xxx-xxx

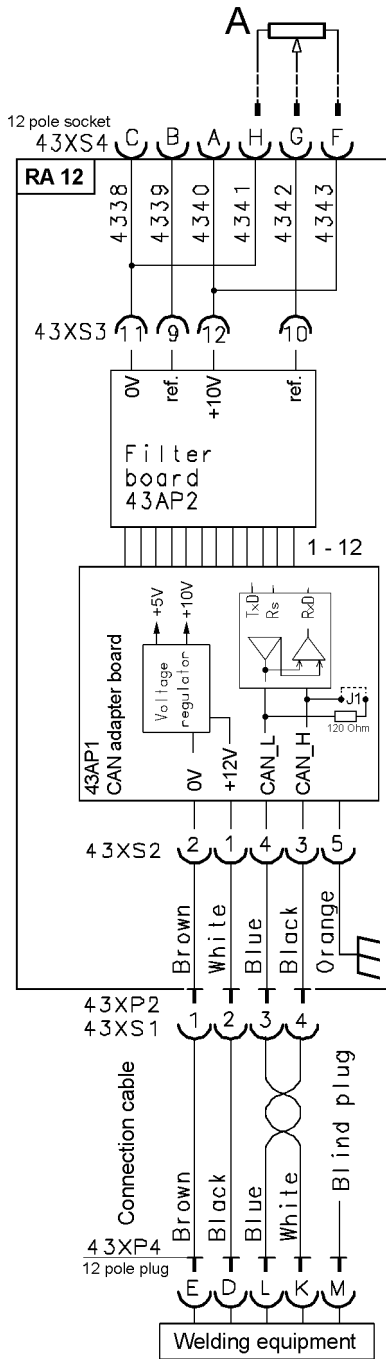

Valid for serial number
638-xxx-xxx

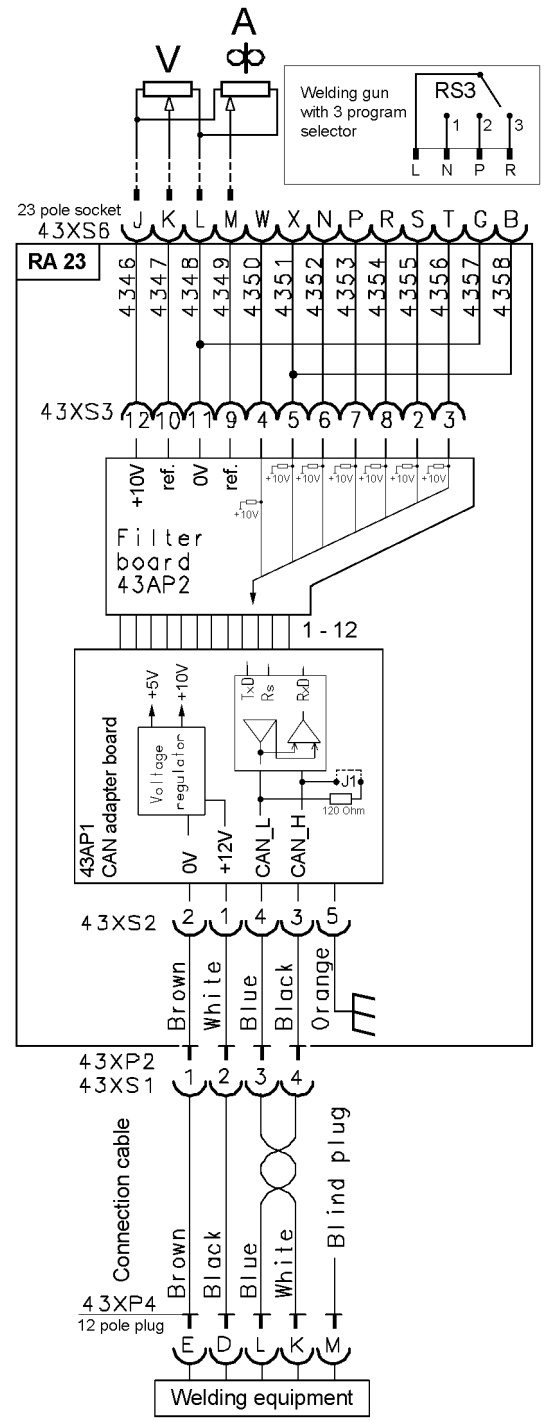
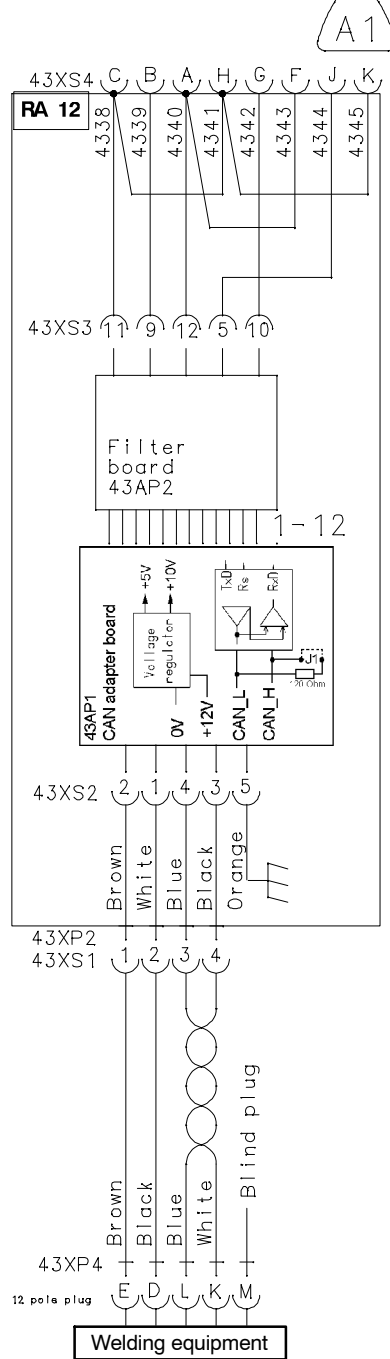

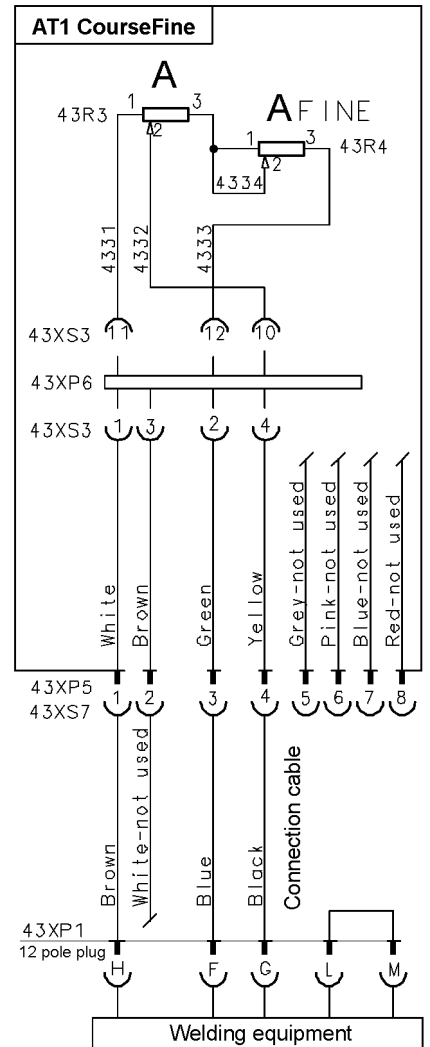
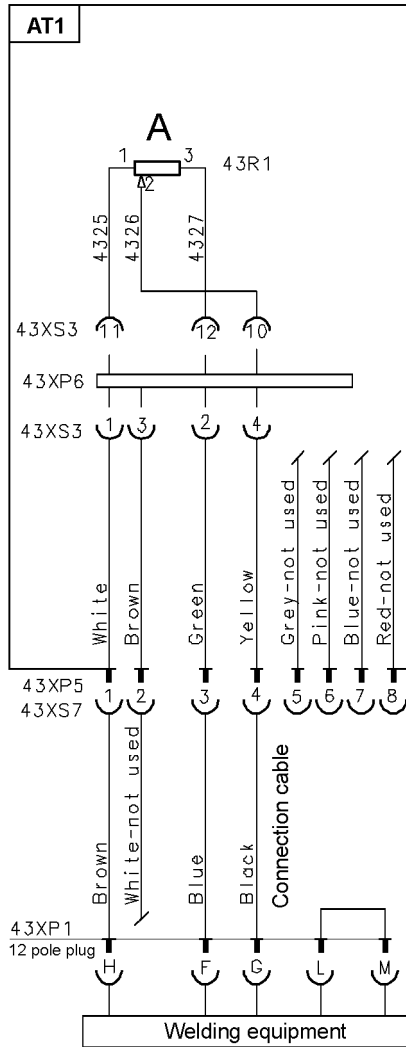
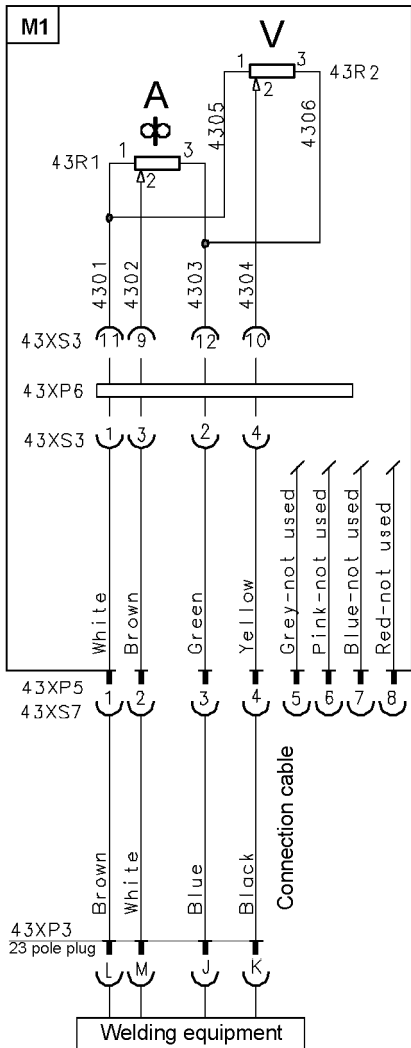

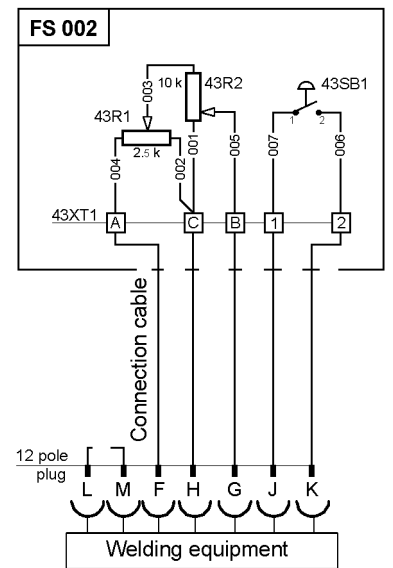
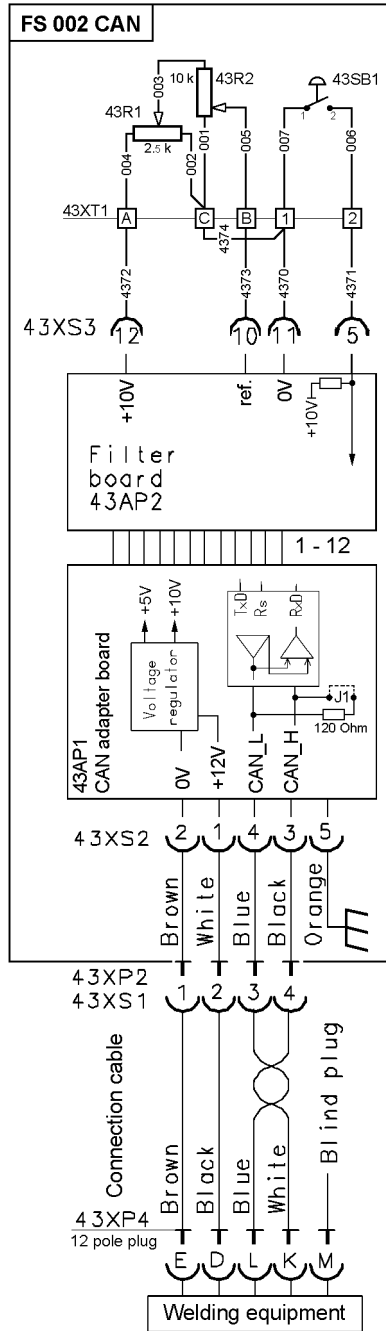
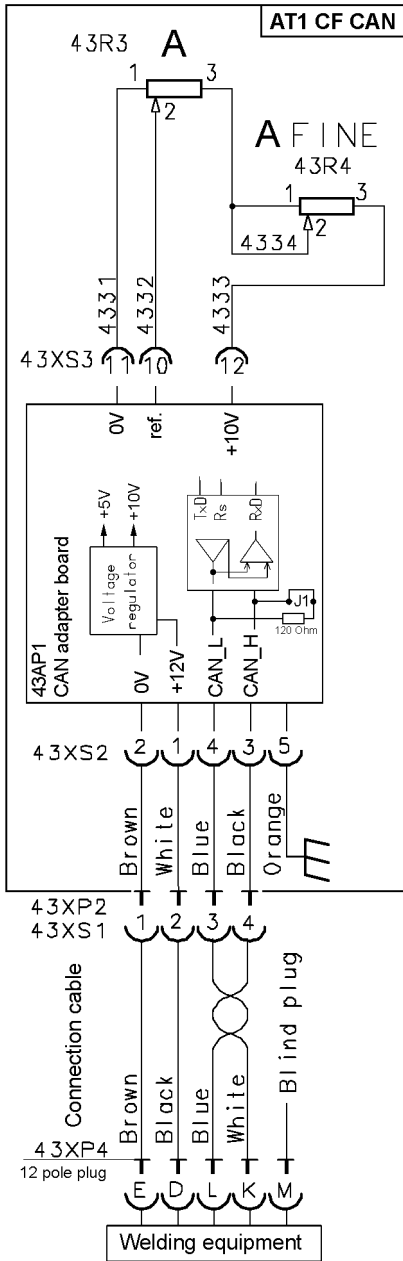

Ordering number

Remote control	Ordering no.	Remote control	Ordering no.
MTA1 CAN 	0459 491 880	M1 	0459 491 895
M1 10Prog CAN 	0459 491 882	AT1 	0459 491 896
AT1 CAN 	0459 491 883	AT1 CoarseFine 	0459 491 897
AT1 CoarseFine CAN 	0459 491 884	RA 12 	0459 491 910
FS 002 CAN 	0349 090 890	RA 23 	0459 491 911
FS 002 	0349 090 886		

Spare parts list 0459 576 990

The spare parts list is available on the Internet at www.esab.com

Accessories

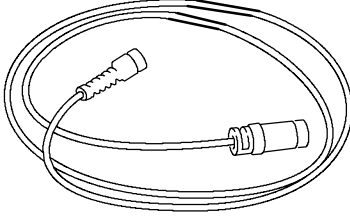
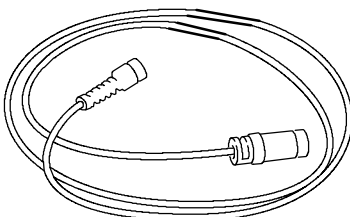
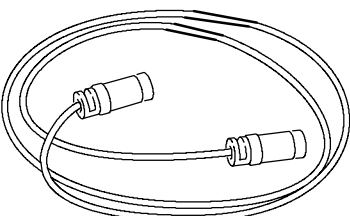
	<p>Remote cable CAN 4 pole - 12 pole</p> <p>5 m 0459 554 880</p> <p>10 m 0459 554 881</p> <p>15 m 0459 554 882</p> <p>25 m 0459 554 883</p> <p>0.25 m 0459 554 884</p> <p>5 m Heavy Duty 0459 554 980</p> <p>Remote cable CAN 4 pole - 10 pole for Yard Feed 2000</p> <p>5 m 0459 960 880</p> <p>5 m Heavy Duty 0459 960 980</p>
	<p>Remote cable 8 pole - 12 pole for remote controls AT1 and AT1 CF</p> <p>5 m 0459 552 880</p> <p>10 m 0459 552 881</p> <p>15 m 0459 552 882</p> <p>25 m 0459 552 883</p> <p>Remote cable 8 pole - 23 pole for remote control M1</p> <p>5 m 0459 553 880</p>
	<p>Extension cable 12 pole for remote controls AT1, AT1 CF and FS 002</p> <p>25 m 0367 662 880</p>

ESAB subsidiaries and representative offices

Europe

AUSTRIA

ESAB Ges.m.b.H
Vienna-Liesing
Tel: +43 1 888 25 11
Fax: +43 1 888 25 11 85

BELGIUM

S.A. ESAB N.V.
Brussels
Tel: +32 2 745 11 00
Fax: +32 2 745 11 28

THE CZECH REPUBLIC

ESAB VAMBERK s.r.o.
Vamberk
Tel: +420 2 819 40 885
Fax: +420 2 819 40 120

DENMARK

Aktieselskabet ESAB
Herlev
Tel: +45 36 30 01 11
Fax: +45 36 30 40 03

FINLAND

ESAB Oy
Helsinki
Tel: +358 9 547 761
Fax: +358 9 547 77 71

FRANCE

ESAB France S.A.
Cergy Pontoise
Tel: +33 1 30 75 55 00
Fax: +33 1 30 75 55 24

GERMANY

ESAB GmbH
Solingen
Tel: +49 212 298 0
Fax: +49 212 298 218

GREAT BRITAIN

ESAB Group (UK) Ltd
Waltham Cross
Tel: +44 1992 76 85 15
Fax: +44 1992 71 58 03

ESAB Automation Ltd
Andover
Tel: +44 1264 33 22 33
Fax: +44 1264 33 20 74

HUNGARY

ESAB Kft
Budapest
Tel: +36 1 20 44 182
Fax: +36 1 20 44 186

ITALY

ESAB Saldatura S.p.A.
Mesero (Mi)
Tel: +39 02 97 96 81
Fax: +39 02 97 28 91 81

THE NETHERLANDS

ESAB Nederland B.V.
Utrecht
Tel: +31 30 2485 377
Fax: +31 30 2485 260

NORWAY

AS ESAB
Larvik
Tel: +47 33 12 10 00
Fax: +47 33 11 52 03

POLAND

ESAB Sp.zo.o.
Katowice
Tel: +48 32 351 11 00
Fax: +48 32 351 11 20

PORTUGAL

ESAB Lda
Lisbon
Tel: +351 8 310 960
Fax: +351 1 859 1277

SLOVAKIA

ESAB Slovakia s.r.o.
Bratislava
Tel: +421 7 44 88 24 26
Fax: +421 7 44 88 87 41

SPAIN

ESAB Ibérica S.A.
Alcalá de Henares (MADRID)
Tel: +34 91 878 3600
Fax: +34 91 802 3461

SWEDEN

ESAB Sverige AB
Gothenburg
Tel: +46 31 50 95 00
Fax: +46 31 50 92 22

ESAB international AB
Gothenburg
Tel: +46 31 50 90 00
Fax: +46 31 50 93 60

SWITZERLAND

ESAB AG
Dietikon
Tel: +41 1 741 25 25
Fax: +41 1 740 30 55

North and South America

ARGENTINA

CONARCO
Buenos Aires
Tel: +54 11 4 753 4039
Fax: +54 11 4 753 6313

BRAZIL

ESAB S.A.
Contagem-MG
Tel: +55 31 2191 4333
Fax: +55 31 2191 4440

CANADA

ESAB Group Canada Inc.
Mississauga, Ontario
Tel: +1 905 670 02 20
Fax: +1 905 670 48 79

MEXICO

ESAB Mexico S.A.
Monterrey
Tel: +52 8 350 5959
Fax: +52 8 350 7554

USA

ESAB Welding & Cutting Products
Florence, SC
Tel: +1 843 669 44 11
Fax: +1 843 664 57 48

Asia/Pacific

CHINA

Shanghai ESAB A/P
Shanghai
Tel: +86 21 5308 9922
Fax: +86 21 6566 6622

INDIA

ESAB India Ltd
Calcutta
Tel: +91 33 478 45 17
Fax: +91 33 468 18 80

INDONESIA

P.T. ESABindo Pratama
Jakarta
Tel: +62 21 460 0188
Fax: +62 21 461 2929

JAPAN

ESAB Japan
Tokyo
Tel: +81 3 5296 7371
Fax: +81 3 5296 8080

MALAYSIA

ESAB (Malaysia) Snd Bhd
Selangor
Tel: +60 3 8027 9869
Fax: +60 3 8027 4754

SINGAPORE

ESAB Asia/Pacific Pte Ltd
Singapore
Tel: +65 6861 43 22
Fax: +65 6861 31 95

SOUTH KOREA

ESAB SeAH Corporation
Kyungnam
Tel: +82 55 269 8170
Fax: +82 55 289 8864

UNITED ARAB EMIRATES

ESAB Middle East FZE
Dubai
Tel: +971 4 887 21 11
Fax: +971 4 887 22 63

Representative offices

BULGARIA

ESAB Representative Office
Sofia
Tel/Fax: +359 2 974 42 88

EGYPT

ESAB Egypt
Dokki-Cairo
Tel: +20 2 390 96 69
Fax: +20 2 393 32 13

ROMANIA

ESAB Representative Office
Bucharest
Tel/Fax: +40 1 322 36 74

RUSSIA

LLC ESAB
Moscow
Tel: +7 095 543 9281
Fax: +7 095 543 9280

LLC ESAB

St Petersburg
Tel: +7 812 336 7080
Fax: +7 812 336 7060

Distributors

For addresses and phone numbers to our distributors in other countries, please visit our home page

www.esab.com



ESAB AB
SE-695 81 LAXÅ
SWEDEN
Phone +46 584 81 000



www.esab.com